

Dotazioni - Equipment

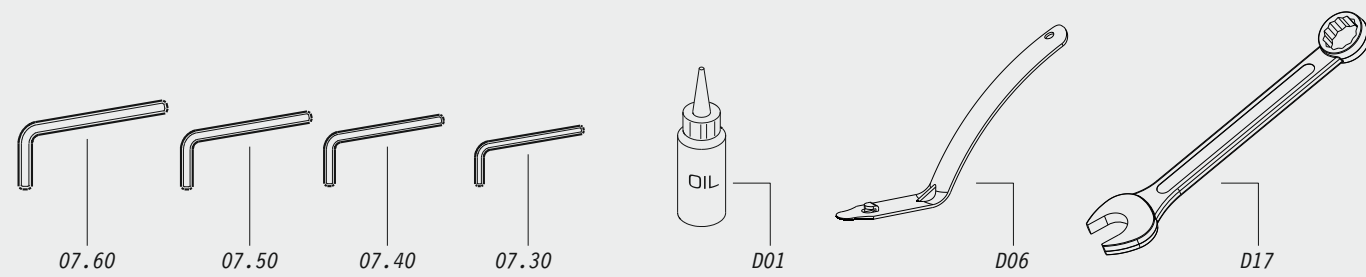

Regolazione aggraffaggio - Stapling adjustment

Note:

1. La graffatrice Jumbo 32.25 viene spedita con le ganasce tipo 25. Le ganasce 32 e 38 sono su richiesta.
The Jumbo 32.25 pneumatic carton stapler is shipped with clincher size 25. Clincher 32 and 38 are on request.
2. La graffatrice Jumbo viene testata prima della spedizione. Se non è necessario non spostare la piastra di regolazione (018).
The jumbo pneumatic stapler is tested before shipping. If not necessary don't move adjust plate (018) position.
3. Scollegare l'alimentazione prima di effettuare le regolazioni.
Disconnect air supply before operating the tool.
4. Per utilizzare graffe di altre misure, sostituire le ganasce con quelle più adatte e regolare la piastra (018) nella posizione indicata.
To operate different leg length staple, please change the suitable clincher and move the adjust plate (018) to suitable position.

APPEARANCE



Staple Leg Length	Anvil Size	Adjusting Plate Position	Threading Depth
25mm	25	6	15mm
28mm		6	15mm
32mm	32	5	18mm
35mm		4	18mm
38mm	38	6	24mm



OMER®

19725T2_JUMBO3225_15118 IV

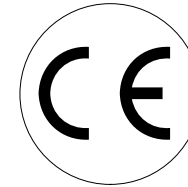

Manuale d'uso, manutenzione e parti di ricambio Parte 2

Use, maintenance and spare parts manual Part.2

JUMBO 32.25

cod. 19725T2

Indice di modifica
Upgrade number

2

Misure impiegabili mm (inch)
Usable lengths mm (inch)

25 ÷ 28
(1" ÷ 1-1/8")

Capacità caricatore n° punti
Magazine capacity No. of fasteners

100

Pressione d'esercizio bar (psi)
Working pressure bar (psi)

5 ÷ 7
(70 ÷ 100)

Consumo aria litri/colpo a 7 bar
Air consumption litres/shot at 7 bar

6,70

Peso kg
Weight kg

6,00

Dimensioni (AxBxH) mm
Dimensions mm

360x174x335

Pressione sonora
Max A-Weighted surface impulse sound pressure level

80 dBA

Potenza sonora emessa
Max A-Weighted impulse sound power level

93 dBA

Vibrazione
Vibration

<2,5 m/s²

omer s.p.a.

Via Foresto, 42 - 31058 SUSEGANA (TV) ITALY
Tel. 0438 455 318 Fax 0438 455 530
e-mail: omer@omer.it www.omer.it

32

1,30x2,25

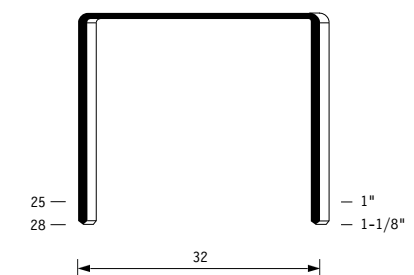

Gauge: 14

Crown: 1.260" (1-1/4")

Tipo di punto
Type of fastener



MANUAL WARNING

Prima di utilizzare la graffatrice

Tutti gli operatori della graffatrice devono leggere questo manuale, per comprendere e seguire le norme di sicurezza e le istruzioni in esso contenute. Conservare questo manuale insieme alla graffatrice per utilizzarlo in caso di necessità. Per qualsiasi altra domanda potete rivolgervi al vostro distributore.

Before operating this stapler

All operator must read this manual, to understand and follow the safety warnings and instructions. Keep these instructions with the stapler for future reference. If you have any question, contact your distributor.

Ref. No. Part No. Description Qty

001	2CRTJM32B001	Cap	1
002	2CRTJM32A002	Packing	2
003	2CRTJM32A003	Cylinder	1
004	2CRTJM32A004	Washer	1
005	2CRTJM32A005	Bumper	1
006	2CRTJM32A006	Washer	2
007	2CRTJM32A007	Piston	1
008	2CRTJM32A008	Packing	1
009	2CRTJM32B009	Handle	1
010	2CRTJM32B010	Valve	1
011	2CRTJM32B011	Tube	1
012	2CRTJM32B012	Cover	1
013	2CRTJM32B013	Rod	1
014	2CRTJM32A014	Bracket	1
015	2CRTJM32A015	Washer	1
016	2CRTJM32B016	Trigger	1
017	2CRTJM32A017	Washer	1
018	2CRTJM32A018	Adjust Plate	1
019	2CRTJM32A019	Front Plate	1
020	2CRTJM32A020	Adjusting Block	1
021	2CRTJM32A021	Adjusting Rod	1
022	2CRTJM32A022	Pin	4
023	2CRTJM32A023	Block	1
024	2CRTJM32A024	Trail Right	1
025	2CRTJM32A025	Trail Left	1
026	2CRTJM32A026	Clincher Seat Right	1
027	2CRTJM32A027	Clincher Seat Left	1
028	2CRTJM32A028	Rod	2
029	2CRTJM32A029	Rod	1
030	2CRTJM32A030	Block Unit	1
031	2CRTJM32A031	Link	2
033	2CRTJM32A032	Rod	4
034	2CRTJM25B034	Clincher x mod.32.25	2
034*	2CRTJM32B034	Clincher x mod.32.32	2
034*	2CRTJM38A034	Clincher x mod.32.38	2
035	2CRTJM32A035	Piston Rod	1
036	2CRTJM32A036	Packing	1
037	2CRTJM32B037	Magazine Seat	1
038	2CRTJM32A038	Block	1
039	2CRTJM32B039	Driver	1
040	2CRTJM32A040	Bracket	2
041	2CRTJM32A041	Magazine Unit	1
041K	2CRTJM32A041K	Magazine kit	
042	2CRTJM32A042	Rod Nut	2
043	2CRTJM32A043	Left Pusher Guide	1
044	2CRTJM32A044	Rod	2
045	2CRTJM32A045	Right Pusher Guide	1
046	2CRTJM32A046	Pusher Unit	1
047	2CRTJM32A047	Roller	1
048	2CRTJM32B048	Spring	1
049	2CRTJM32A049	Spring	1
050	2CRTJM32B050	Silencer	1
053	2CRTJM32B053	Grip	1
501	2CRTJM32B501	Hex.Soc.Hd.Bolt	4
502	2CRTJM32B502	Lock Nut	1
503	2CRTJM32A503	O-Ring	1
504	2CRTJM32A504	O-Ring	1
505	2CRTJM32A505	Round Hd Nut	1
506	2CRTJM32A506	Hex.Soc.Hd.Bolt	6
507	2CRTJM32A507	Hex.Hd.Bolt	1
508	2CRTJM32A508	Spring Washer	1
509	2CRTJM32B509	Nut	1
510	2CRTJM32B510	O-Ring	4
511	2CRTJM32A511	O-Ring	1
512	2CRTJM32A512	O-Ring	1
513	2CRTJM32A513	Hex.Soc.Hd.Bolt	4
514	2CRTJM32A514	C-Ring	2
515	2CRTJM32A515	Lock Nut	4
516	2CRTJM32A516	Spring Pin	1
517	2CRTJM32A517	Hex.Flat. Hd.Screw	1
518	2CRTJM32A518	Hex.Flat. Hd.Screw	1
519	2CRTJM32A519	Lock Nut	1
520	2CRTJM32A520	Hex.Soc.Hd.Bolt	2
521	2CRTJM32A521	Washer	4
522	2CRTJM32A522	Hex.Soc.Hd.Bolt	4
523	2CRTJM32A523	Hex.Soc.Hd.Bolt	6
524	2CRTJM32A524	O-Ring	1
525	2CRTJM32A525	Spring Pin	1
526	2CRTJM32B526	Hex.Soc.Hd.Bolt	2
527	2CRTJM32A527	Air Plug	1
528	2CRTJM32A528	Fixing Blot	1
529	2CRTJM32A529	Spring Washer	5
530	2CRTJM32A530	Hex.Soc.Hd.Bolt	2
531	2CRTJM32B531	O-Ring	1
532	2CRTJM32B532	O-Ring	1
533	2CRTJM32B533	O-Ring	1
534	13.25	Pin	1

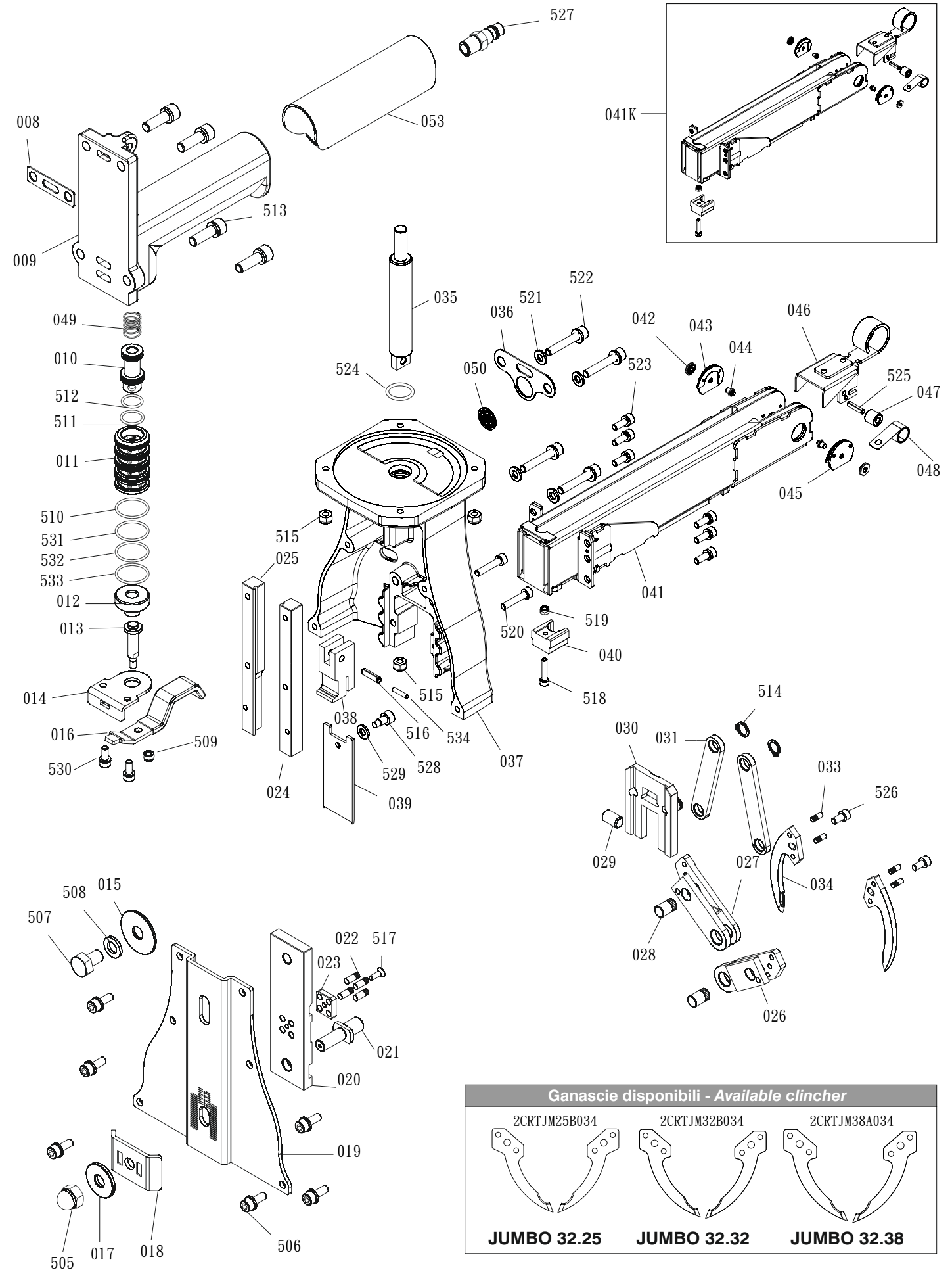
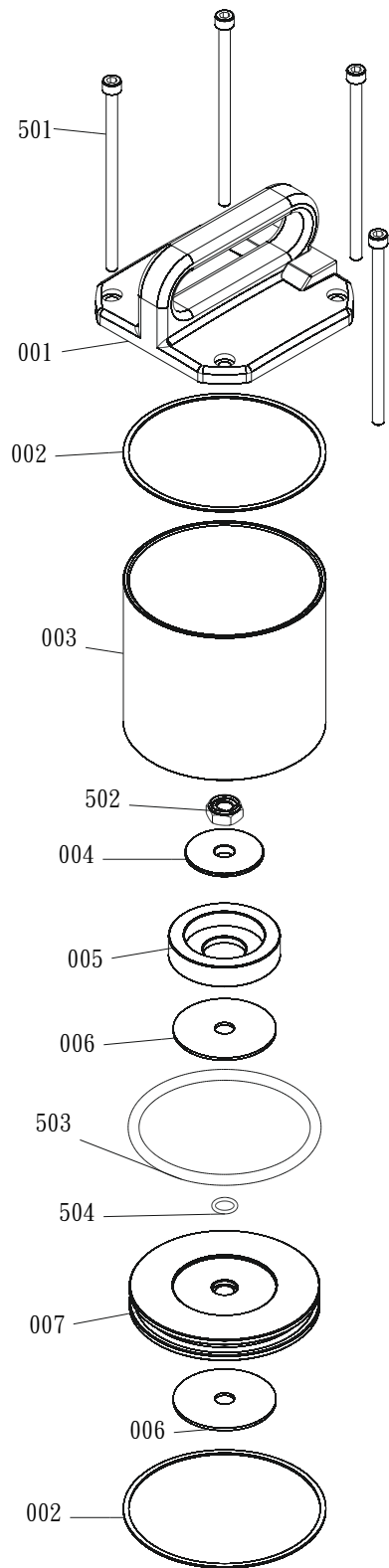

* on request

19725T2_JUMBO3225_15118 IV

Parti di ricambio - Spare parts

JUMBO 32.25

cod. 19725T2

Indice di modifica Upgrade number

2

202809